

PACKAGE DIMENSIONS inch (mm)

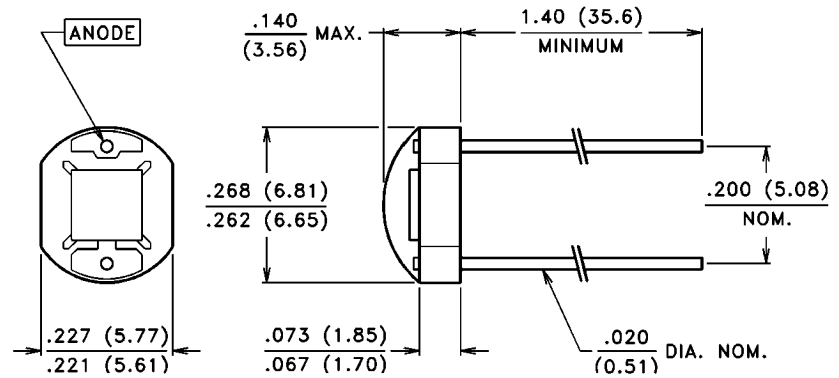

CASE 11 CERAMIC
CHIP ACTIVE AREA: .008 in² (5.16 mm²)

PRODUCT DESCRIPTION

Planar silicon photodiode mounted on a two lead ceramic substrate and coated with a thick layer of clear epoxy. These diodes have very high shunt resistance and have good blue response.

ABSOLUTE MAXIMUM RATINGS

Storage Temperature:

-20°C to 75°C

Operating Temperature:

-20°C to 75°C

RoHS Compliant



ELECTRO-OPTICAL CHARACTERISTICS @ 25°C (See also VTB curves, pages 21-22)

SYMBOL	CHARACTERISTIC	TEST CONDITIONS	VTB8341H			UNITS
			Min.	Typ.	Max.	
I _{SC}	Short Circuit Current	H = 100 fc, 2850 K	35	60		μA
TC I _{SC}	I _{SC} Temperature Coefficient	2850 K		.12	.23	%/°C
V _{OC}	Open Circuit Voltage	H = 100 fc, 2850 K		490		mV
TC V _{OC}	V _{OC} Temperature Coefficient	2850 K		-2.0		mV/°C
I _D	Dark Current	H = 0, V _R = 2.0 V			100	pA
R _{SH}	Shunt Resistance	H = 0, V = 10 mV		1.4		GΩ
TC R _{SH}	R _{SH} Temperature Coefficient	H = 0, V = 10 mV		-8.0		%/°C
C _J	Junction Capacitance	H = 0, V = 0		1.0		nF
S _R	Sensitivity	365 nm		.10		AW
λ _{range}	Spectral Application Range		320		1100	nm
λ _p	Spectral Response - Peak			920		nm
V _{BR}	Breakdown Voltage		2	40		V
θ _{1/2}	Angular Resp. - 50% Resp. Pt.			±60		Degrees
NEP	Noise Equivalent Power			2.4 x 10 ⁻¹⁴ (Typ.)		W/√Hz
D*	Specific Detectivity			9.7 x 10 ¹² (Typ.)		cm√Hz/W

VTB Process Photodiodes

VTB PROCESS BLUE ENHANCED, ULTRA HIGH DARK RESISTANCE

FEATURES

- *Enhanced UV to IR spectral range*
- *Integral IR rejection filters available*
- *Response @ 220 nm, 0.06 A/W, typical with UV window*
- *Response @ 365 nm, 0.14 A/W typical*
- *High open circuit voltage @ low light levels*
- *1 to 2% linearity over 7 to 9 decades*
- *Very low dark current & high shunt resistance*

PRODUCT DESCRIPTION

This series of P on N silicon planar photodiodes have been designed to maximize their response through the visible part of the spectrum. Those units with UV transmitting windows also exhibit excellent response in the UV region and are characterized at 220 nm.

"B" series devices have a built-in infrared rejection filter for those applications where a detector is needed that approximates the human eye. Typical transmission of wavelengths greater than 750 nm is less than 3% when measured with an incandescent source operating at 2850 K.

Diodes made with the VTB process are primarily intended for use in the photovoltaic mode but may be used with a small reverse bias. All photodiodes in this series exhibit very high shunt resistance. This characteristic leads to very low offsets when the diodes are used in high gain transimpedance op-amp circuits.

TYPICAL CHARACTERISTIC CURVES @ 25°C (UNLESS OTHERWISE NOTED)

Absolute Spectral Response

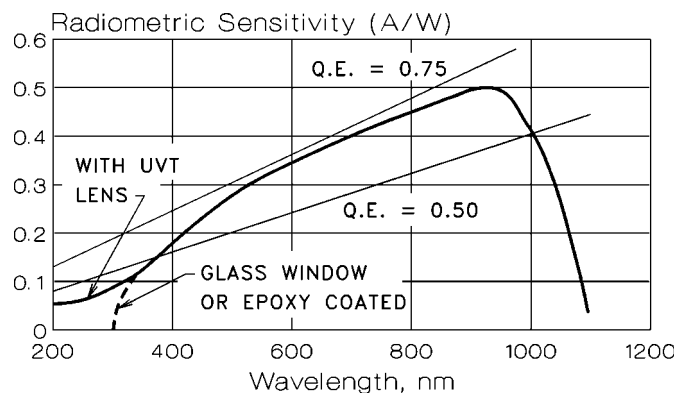

Absolute Spectral Response "B" Series (Filtered)

